

## SNAP-TIE SPACING

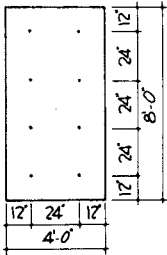

8 HOLE 24"x24" tie spacing uses the fewest ties and is for low walls, slow rate of pour, or where the work is backfilled.

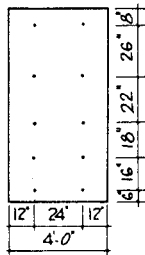

STAGGERED SYSTEM uses only 10 ties. Suitable for fast pours to 8' heights. Mark panels for one-way up erection.

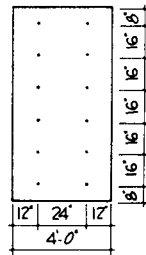

16"x24" spacing is for all purpose work. Most pours can be done using this tie spacing.

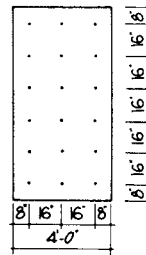

16"x16" SPACING is for fast pour rates or architectural finishes.

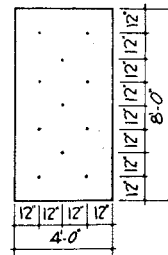

THE ELEVEN HOLE ADAPTATION ON THE 24"x24" snap-tie layout shown at left retains the advantages of the eight-hole layout and permits faster rates of pour with any height walls. It is the most versatile and economical snap-tie spacing.

Panels drilled with eight holes now in use may be adapted to this eleven-hole layout and the panel may then be used as a 8, 9, 10, or 11-hole, depending on pressures. The panels may be used horizontally or vertically in any combination.

In practice, rarely more than 9 or 10 ties are needed per 4'x8' panel.

SNAP-TIE SPACING WILL DEPEND ON THE TEMPERATURE, RATE-OF-POUR AND PLYWOOD THICKNESS. WHEN IN DOUBT, CONSULT YOUR RATE-OF-POUR CHARTS.

## PREPARATION:

Gang drilling of plywood is the only preparation required with the Jahn Forming Method.

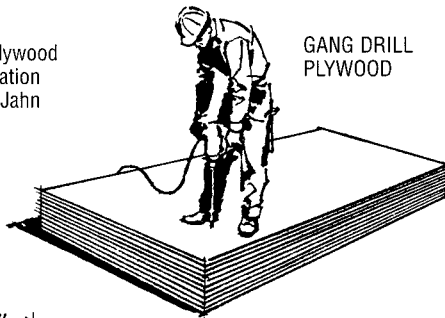

GANG DRILL PLYWOOD

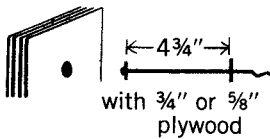

with 3/4" or 5/8" plywood

5/8" or 3/4" plywood may be used. Although 5/8" is slightly lower in cost, 3/4" is stronger, lasts longer, uses fewer ties and brackets and is more economical in the long run.

**NOTE:** 11/16" eccentric take-up on Bracket allows 4 7/8" tie to be used with either 3/4" or 5/8" plywood.

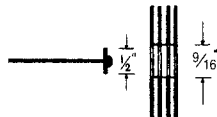

Holes 1/8" larger than tie end.

Holes should be drilled 1/8" larger than tie-end. This will usually be 9/16" or 5/8"

## 3. INSTALL TIES AND "A" BRACKETS



Insert snap ties. Any standard 4 7/8" end 3000# snap tie will work with the Jahn "A" Bracket and 3/4" plywood. Use 4 3/4" end ties with 5/8" plywood.

Two men can do this job with speed and economy if one installs the ties and the other puts on the Jahn "A" Brackets.

## 4. JAHN "A" BRACKET FEATURES

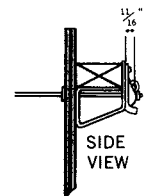
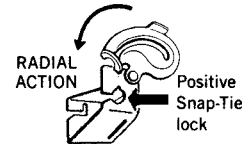
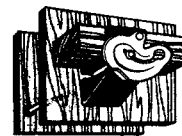

Jahn Brackets, employing the patented eccentric, are the only brackets that positively will not vibrate loose under internal vibration. Note the following features: (1) Brackets can be installed either before or after the walers are in place. (2) The bracket slots slip easily over the tie end. No laborious threading through a hole in the body. (3) The tie seats positively in the slot end. (4) The radial action of the eccentric has a drawing instead of a shearing action against the tie head. (5) The offset fastening of the eccentric on the body helps keep the eccentric from loosening under vibration. (6) Pressure of the bracket body is against the 2x4 instead of the plywood.

## SNAP-TIE BREAKBACK

For best results, break off snap-tie ends using the Sansoe snap-tie socket wrench.

A function of plastic ties is to aid in the breakback operation, therefore Sansoe Concrete Specialties cannot guarantee that no-cone ties will consistently provide proper breakback.

In all cases, break off ends of snap-ties as the concrete has hardened.

**5. PROPER "A" BRACKET INSTALLATION**

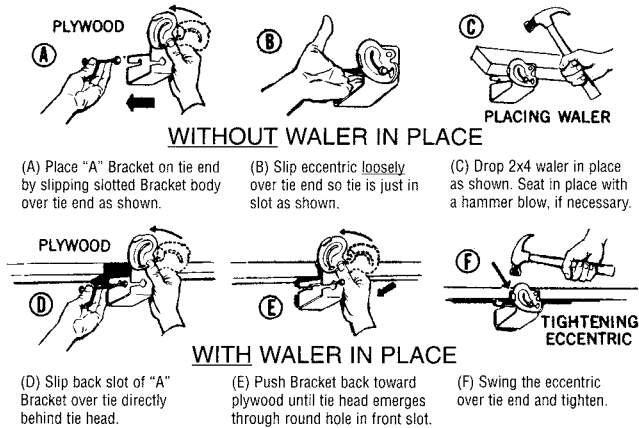

**6. LOW WALLS**

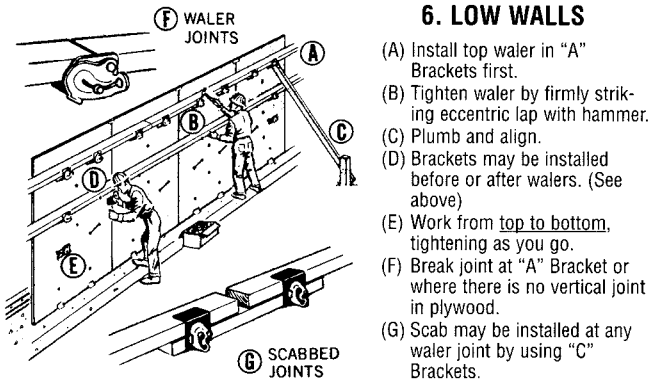

**7. INSIDE WALLS**

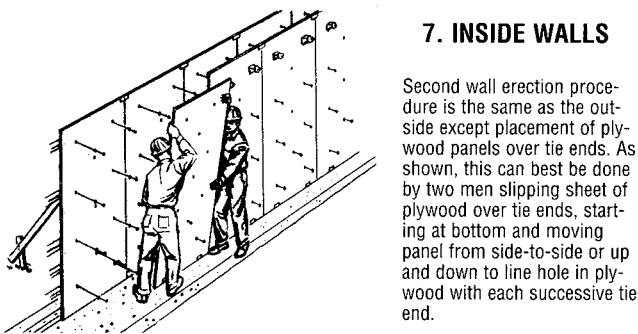

**LOW WALL APPLICATIONS**

**WALLS TO 4 FEET**

With 4x8 plywood panels horizontal, the eleven-hole tie spacing allows an extra 2x4 waler, when required for faster pours. The alternate ties and brackets could be left out in top row. Form spreaders at top.

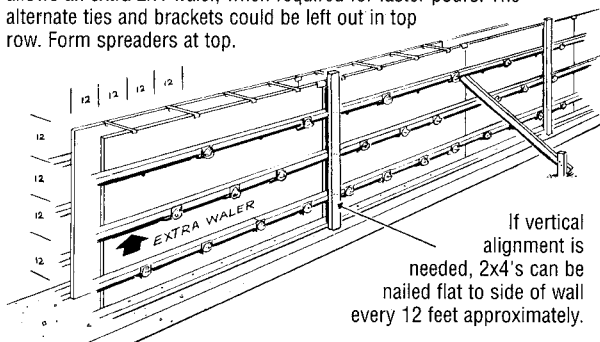

**8. OUTSIDE CORNERS**

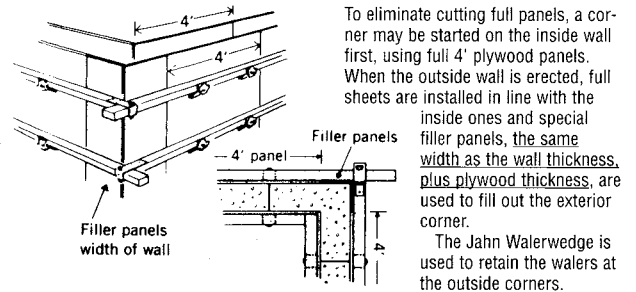

**9. JAHN WALERWEDGE**

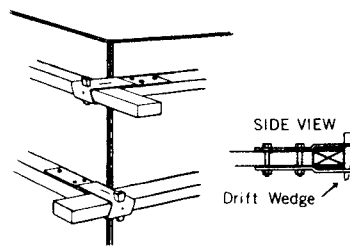

**10. INSIDE CORNERS**

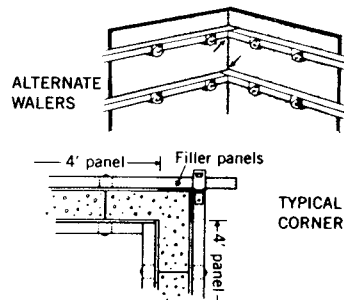

**TURN PAGE FOR FURTHER INFORMATION**

**WALLS TO 8 FEET**

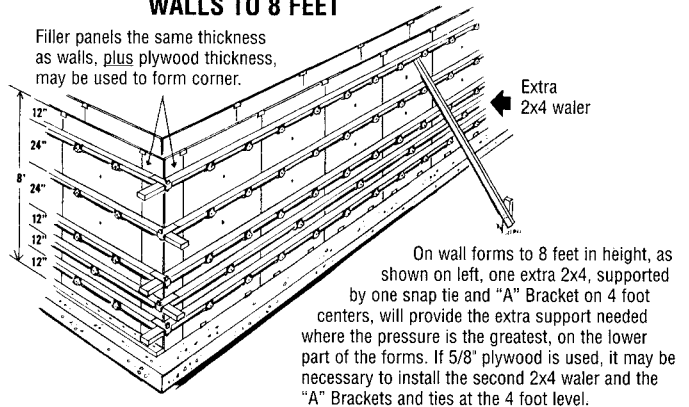

## HIGH WALL APPLICATIONS

### 1. ERECT STRONGBACKS

WITH JAHN "C" BRACKETS

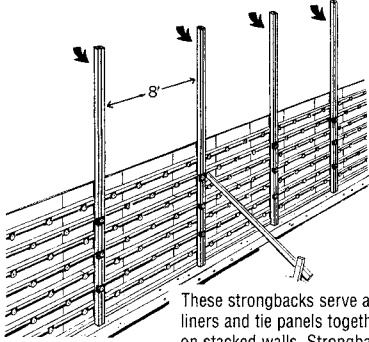

These strongbacks serve as liners and tie panels together on stacked walls. Strongbacks should be spaced every 8' on the average work, using Jahn "C" Brackets with Jahn Tie Extenders or standard 8 1/2" end 3000# snap ties. Loose 2x4's are used for the strongbacks with Jahn "C" Brackets and do not require any nails or spacers (5/8" spacing between walers allows for snap tie).

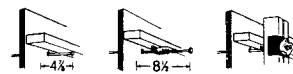
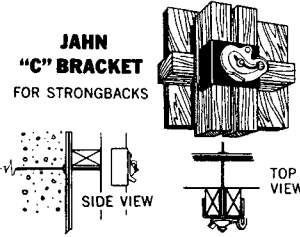

FOR USE WITH JAHN "C" BRACKETS Form strongbacks anywhere on wall. Eliminates need for special ties where strongbacks are used on one side only.

### 3. INSTALL JOINT COVER

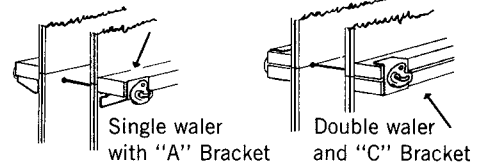

Above are two suggested methods of covering joint when stacking plywood. With single waler, drill holes down 1 1/8" in bottom sheet and put tie, "A" Bracket and waler in place before adding second plywood sheet. Tack top sheet to waler.

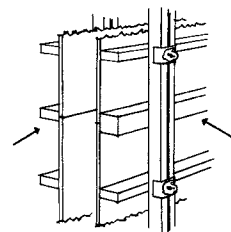

Single loose 2x4 or 4x4 joint coverage: Tack waler to lower plywood sheet and hold in place with strongbacks on 6' to 8' centers.

### 2. INSTALL JAHN SCAFFOLD JACKS

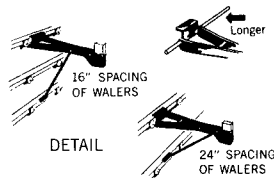
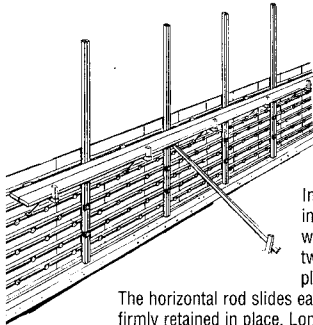

Install Scaffold Jacks after strongbacks are in place but prior to installing joint cover walers. The Jahn Scaffold Jack will hold two 2x10 planks for a comfortable working platform.

The horizontal rod slides easily through the "A" Bracket body and is firmly retained in place. Long end of rod should be slipped in first. The Scaffold Jack has an adjustable support leg for use with either 16" or 24" tie and waler spacing. A safety guard rail socket is provided. Safety nailing holes are provided for securing Jack to both top and bottom support waler.

### 4. INSTALL SECOND LIFT OF PLYWOOD

- Lift plywood sheet in place.
- Tack bottom to joint cover waler.
- Hold plywood in place with short 2x4 spacer and Jahn "C" Bracket.
- Set additional panels, tacking to joint cover waler and securing to previously installed panel with Jahn Ply Holders.
- Install snap ties, brackets, and walers, working from bottom to top. Brackets can be installed either before or after walers are in place.

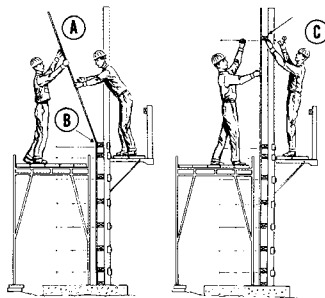

Spacer may be used to hold plywood in place.

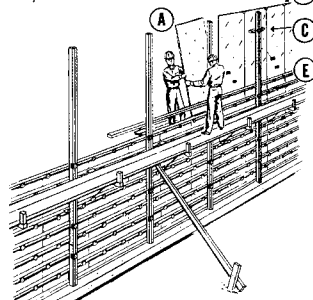
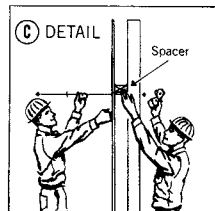

- ERECT STRONGBACKS (SEE ILLUSTRATION, UPPER LEFT)
- INSTALL SCAFFOLD JACKS (SEE ILLUSTRATION, LEFT)
- INSTALL JOINT COVER (SEE ILLUSTRATION, UPPER RIGHT)
- INSTALL SECOND LIFT OF PLYWOOD (SEE ILLUSTRATION, LOWER LEFT)

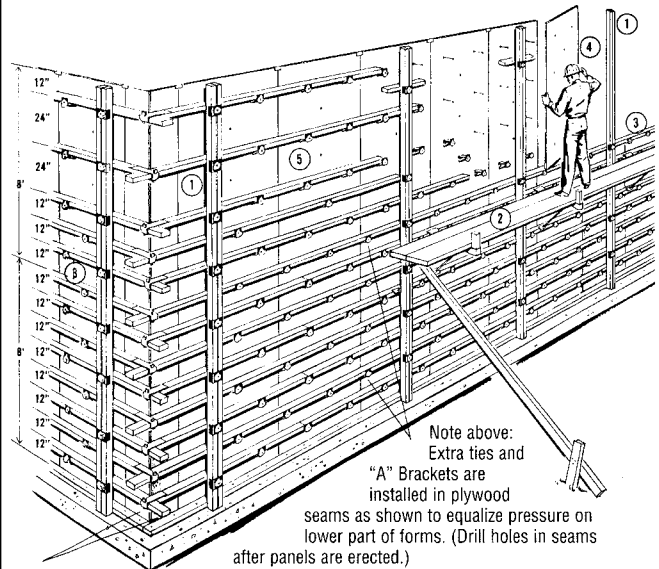

Note above: Extra ties and "A" Brackets are installed in plywood seams as shown to equalize pressure on lower part of forms. (Drill holes in seams after panels are erected.)

OPTIONAL CORNER FILLER PANELS

(5) NOTE ABOVE: FEWER TIES AND WALERS ARE REQUIRED IN THE TOP 5' OF FORMS WHEN 3/4" PLYWOOD IS USED, AS THE FORM PRESSURE STARTS DECREASING HERE.

## RADIUS FORMING

### Radius Forming Notes

MCS recommends a system for radius forming involving Jahn "A" brackets, snapties, and —to avoid filler strips—trimmed interior plywood.

### BENDING RADIUS

| Minimum Bending Radius for Plywood Panels |                     |                          |
|---|---------------------|--------------------------|
| Panel Thickness/Inches                    | Curved Across Grain | Curved Parallel to Grain |
| 1/4"                                      | 2'-0"               | 5'-0"                    |
| 3/8"                                      | 3'-0"               | 8'-0"                    |
| 1/2"                                      | 6'-0"               | 12'-0"                   |
| 5/8"                                      | 8'-0"               | 16'-0"                   |
| 3/4"                                      | 12'-0"              | 20'-0"                   |

\*Suggested by ACISP-4 for average work based on information supplied by APA.

### Tie Spacing

This special drilling layout allows single 2 x 4 stud coverage of vertical panel joint whether joint is continuous or panels are staggered. Caution: Be sure that holes drilled 1-1/8" in from panel edge are to the right as shown, whether used on interior or exterior wall form.

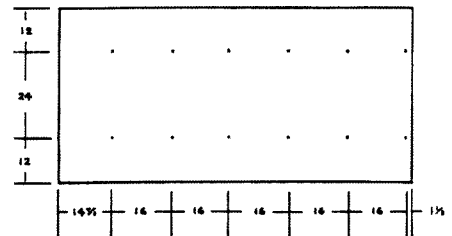

### Form Construction

- Using 1-1/8" plywood, cut a template to conform to the desired radius (reduce radius to compensate for thickness of studs and plywood).
- Set back to compensate for thickness of studs and plywood and nail template to footing.
- Toenail studs to template.
- Tack plywood to first stud and install snapties and "A" brackets to secure plywood to remaining studs. "A" brackets should always be set on the left side of studs so eccentric is properly positioned to be vibration proof.
- Temporarily brace using adjustable form aligner braces.
- Continue for additional sheets, staggering plywood joints as panels are stacked.
- Check and align form; cut top template to conform to full radius minus plywood thickness and nail template to top of form.
- Double-up —outside form will conform to the radius of the inside form.

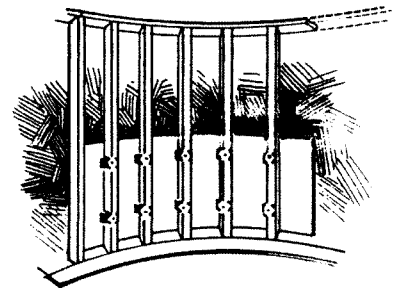

### Plywood Trimming

To eliminate the need for exterior panel filler strips, plywood for the inside forms may be trimmed to compensate for the difference in circumference. Measure 1-1/8" in from panel edge, and adjust spacing for subsequent holes accordingly. For heavy duty radius forming jobs, ask your MCS rep for info on **Gates Radius Forming Systems**.

